



Tosca Magnum Optimum 1210

The smarter choice for bulk transport



Featuring smooth walls that are ideal for dry bulk food or non-food, this foodgrade virgin PP industrial size heavy duty Folding Large Container (FLC) saves space in your warehouse and during return transport, reducing costs and carbon footprint. Its durable structure and two runners ensure strength and stability throughout the supply chain, even when the container is open or folded.

An ergonomic drop door on the long side ensures safe, easy handling and quick access when folding, unfolding, or picking.

Design & Features



Optimise storage and transport efficiency

This heavy-duty, food-grade PP FLC saves space in your warehouse and on return trips — optimising storage and transport efficiency.



Handle containers easy and safely

The container features a drop door and three runners for easy handling.



Reduce product waste and associated costs

Bottom discharge is specifically designed to reduce residual product.



Meet PPWR and EPR goals with reusable containers

100% recyclable at end of life and PPWR-compliant.



Scan this QR to **discover more** about this product.

Specifications



Characteristics

Colour	Grey/Black
Runners	2
Lid	Included
Drop door	2
Bottom discharge	No
Material	PP
Foodgrade	Yes
ISPM-15 proof	Yes
Temperature range	-30°C/+40°C



Dimensions

External	1200 x 1000 x 1000 mm
Internal	1140 x 940 x 815 mm
Folded	1200 x 1000 x 325 mm
Weight	57,2 Kg
Volume	873 l



Loading quantities

Units per trailer (with/without lid) 208 / 234 units

Stack (with/without lid) 8 / 9 units



Load capacity

Max static load	3.200 kg
Max dynamic load	1.600 kg
Max in rack load	750 kg

Technical Drawing

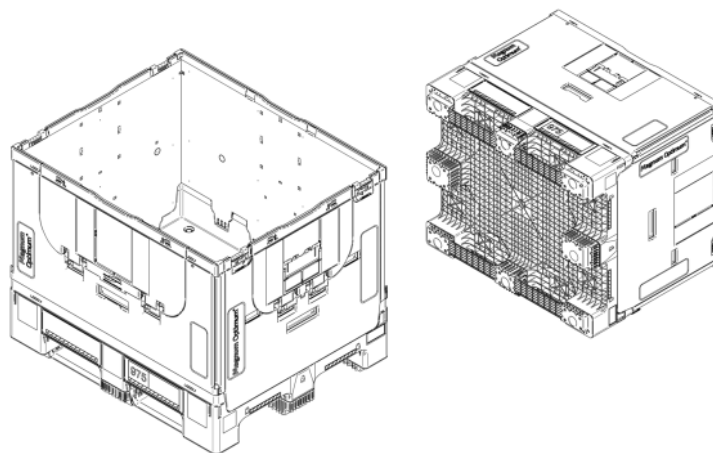

Disclaimer

- Temperature ranges, dimensions, weights, volumes and loading capacities listed are estimates and may vary due to handling, manufacturing tolerances, and regulatory differences. Any deviation from the specified temperature range must be confirmed with Tosca.
- Users must assess product suitability and conduct appropriate risk assessments before use.
- All users must follow Tosca's specifications and Health & Safety Guidelines and use outside these parameters is at the user's risk.